

The FG Wilson fully weatherproof sound attenuated (SA) enclosure reduces sound levels to comply with the new European Community regulations 2000/14/EC which became effective on 1 January 2002.

These enclosures incorporate internally mounted exhaust silencers and are of extremely rugged construction in order to withstand the rough handling common on many construction sites. The panel is viewed through a hinged perspex window.

Highly Corrosion Resistant Construction

- ▶ Stainless steel locks
- ▶ Black zinc die cast hinges on gullwing doors tested and proven to withstand extremely corrosive conditions
- ▶ Zinc plated or stainless steel fasteners and hinges
- ▶ Body made from steel components pre-treated with zinc phosphate prior to polyester powder coating

Excellent Access for Maintenance

- ▶ Top hung gullwing doors
- ▶ Hinged and lockable end panels
- ▶ Radiator fill access through radiator end panel
- ▶ Lube oil drain piped to exterior of the canopy

Security and Safety

- ▶ Perspex control panel viewing window in a lockable access door
- ▶ Emergency stop button mounted on canopy exterior
- ▶ End panels secured by internal latches with safety retainer
- ▶ Cooling fan and battery charging alternator fully guarded
- ▶ Fuel fill and battery can only be reached via lockable access doors
- ▶ Exhaust silencing system enclosed for operator safety

Transportability

- ▶ Tested and certified single point lifting facility
- ▶ Pallet truck and forklift truck pockets

Optional Features

- ▶ Lockable vandal proof control panel cover in place of window.



10 - 22 kVA
Range



Modular
Acoustic Enclosure



Sound Pressure Levels (dba)

		50 Hz at 1500 RPM						60 Hz at 1800 RPM					
		15 m (50 ft)		7 m (23 ft)		1 m (3 ft)		15 m (50 ft)		7 m (23 ft)		1 m (3 ft)	
Generating Set Model	LWA	75% Load	100% Load	75% Load	100% Load	75% Load	100% Load	75% Load	100% Load	75% Load	100% Load	75% Load	100% Load
P12.5P2	92	61.3	62.3	67.3	68.3	77.4	78.4	62.0	62.0	68.0	68.0	79.0	79.0
P13.5E2	92	61.3	62.7	67.3	68.7	77.4	79.1	62.0	62.0	68.0	68.0	79.0	79.0
P16.5P2	91	59.1	60.4	65.1	66.4	76.2	77.1	61.4	62.0	67.4	68.0	77.4	78.4
P18E2	91	59.1	61.9	65.1	67.9	76.2	77.3	61.4	62.8	67.4	68.8	77.4	79.2
P20P2	91	60.1	61.8	66.1	67.8	76.7	78.6	61.4	62.8	67.4	68.8	77.4	79.2
P22E2	91	60.1	62.3	66.1	68.3	76.7	78.9	61.4	65.0	67.4	71.0	77.4	81.0
P10P2S	92	61.3	62.3	67.3	68.3	77.4	78.4	62.0	62.0	68.0	68.0	79.0	79.0
P11E2S	92	61.3	62.7	67.3	68.7	77.4	79.1	62.0	62.0	68.0	68.0	79.0	79.0
P13P2S	91	59.1	60.4	65.1	66.4	76.2	77.1	61.4	62.0	67.4	68.0	77.4	78.4
P14E2S	91	59.1	61.9	65.1	67.9	76.2	77.3	61.4	62.8	67.4	68.8	77.4	79.2
P15P2S	91	60.1	61.8	66.1	67.8	76.7	78.6	61.4	62.8	67.4	68.8	77.4	79.2
P16.5E2S	91	60.1	62.3	66.1	68.3	76.7	78.9	61.4	65.0	67.4	71.0	77.4	81.0

Levels in accordance with European Noise Directive (2000/14/EC)

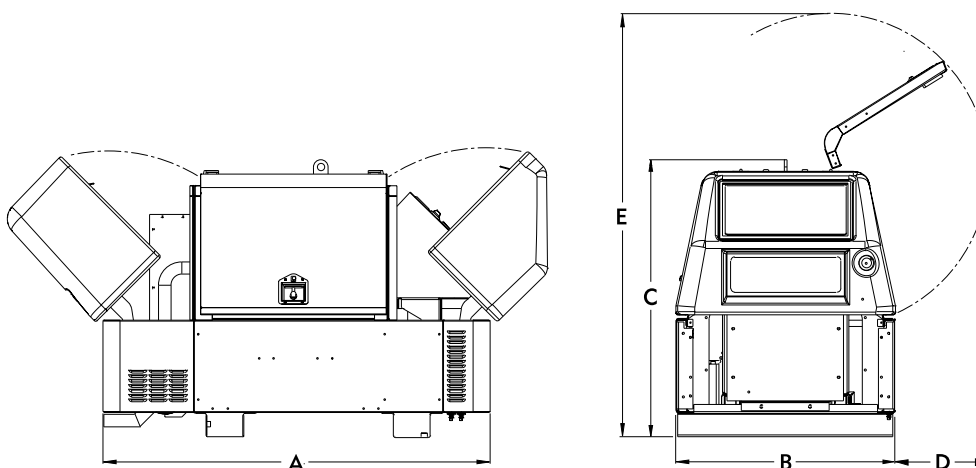

Dimensions and Weights

Generating Set Model	A mm (in)	B mm (in)	C mm (in)	D mm (in)	E mm (in)	Weight L (US Gal)	Fuel Capacity Kg (lb)
P12.5P2/P13.5E2	1593 (62.7)	900 (35.4)	1275 (50.2)	388 (15.3)	1839 (72.4)	580 (1279)	45 (12)
P16.5P2/P18E2	1593 (62.7)	900 (35.4)	1275 (50.2)	388 (15.3)	1839 (72.4)	641 (1413)	45 (12)
P20P2/P22E2	1593 (62.7)	900 (35.4)	1275 (50.2)	388 (15.3)	1839 (72.4)	654 (1442)	45 (12)
P10P2S/P11E2S	1593 (62.7)	900 (35.4)	1255 (49.4)	388 (15.3)	1839 (72.4)	580 (1279)	45 (12)
P13P2S/P14E2S	1593 (62.7)	900 (35.4)	1255 (49.4)	388 (15.3)	1839 (72.4)	641 (1413)	45 (12)
P15P2S/P16.5E2S	1593 (62.7)	900 (35.4)	1255 (49.4)	388 (15.3)	1839 (72.4)	654 (1442)	45 (12)

Note: Net Weight with lube oil, no coolant, no fuel; *Clearance required both sides.



FG Wilson (Engineering) Ltd
 Old Glenarm Road, Larne, County Antrim BT40 1EJ
 Northern Ireland, United Kingdom
 Tel: +44 (0) 28 2826 1000 Fax: +44 (0) 28 2826 1111
www.FGWilson.com

